

SG1 Series

Regulators - Pressure Reducing

DSG012031X012

Specifications

For questions about this product, please consult TESCOM.

OPERATING PARAMETERS

Pressure rating per criteria of CGA E-4; ASME B31; ASME BPVC

Maximum Inlet Pressure

C_v = 0.06: 4500 psig / 310 bar

C_v = 0.2: 3000 psig / 207 bar

Maximum Outlet Pressure

15, 25, 50, 125, 250 psig

103, 172, 345, 862, 1724 kPa

1.0, 1.7, 3.4, 8.6, 17.2 bar

Design Proof Pressure

150% maximum rated

Leakage

Internal: Bubble-tight

External: Designed to meet

$< 2 \times 10^{-8}$ atm cc/sec He / $< 2 \times 10^{-8}$ mbar l/s He

Operating Temperature

PCTFE seat: -40°F to 140°F / -40°C to 60°C

Vespel® seat: -40°F to 250°F / -40°C to 121°C

Flow Capacity

C_v = 0.06, 0.2

Decaying Inlet Characteristic

C_v = 0.06

0.37 psig / 100 psig

0.03 bar / 6.9 bar

C_v = 0.2

1.45 psig / 100 psig

0.10 bar / 6.9 bar



TESCOM SG1 Series is a compact, lightweight high purity single-stage regulator for specialty and industrial gas flows of less than 10 SCFM / 283 SLPM. Sensitive, extra long-life metal diaphragm ensures gas purity and integrity. User-friendly model number enables the specifier to select optional gauges, relief and shut-off valves, and cylinder connections as part of the regulator assembly.

Applications

- Laboratory and Point-of-Use Gas Systems in medical, pharmaceutical, food and beverage, and other high purity applications
- Process analyzer gases, metal fabrication and specialty and industrial gas cylinders

Features and Benefits

- Cartridge valve design incorporates a 10 micron filter that protects the regulator seat and makes service simple
- Optional neoprene diaphragm provides exceptional sensitivity for precise pressure control

MEDIA CONTACT MATERIALS

Body

316L Stainless Steel, Nickel-Plated Brass

Seat

PCTFE, Vespel®

Diaphragm

316L Stainless Steel, Neoprene

Filter

10 micron nominal sintered Bronze

10 micron nominal sintered 316 Stainless Steel

Seal

Teflon® or Buna-N

Remaining Parts

Brass, 300 Series Stainless Steel

OTHERS

Connections

Inlet and outlet: 1/4" NPTF

Accessories: 1/4" NPTF

Cleaning

CGA 4.1 and ASTM G93

Weight

2.4 lbs / 1.1 kg

Teflon® and Vespel® are registered trademarks of E.I. du Pont de Nemours and Company.

TESCOM

www.tescom.com

EMERSON
Process Management

SG1 Series Regulator Drawing

5 Ports
(Top view)

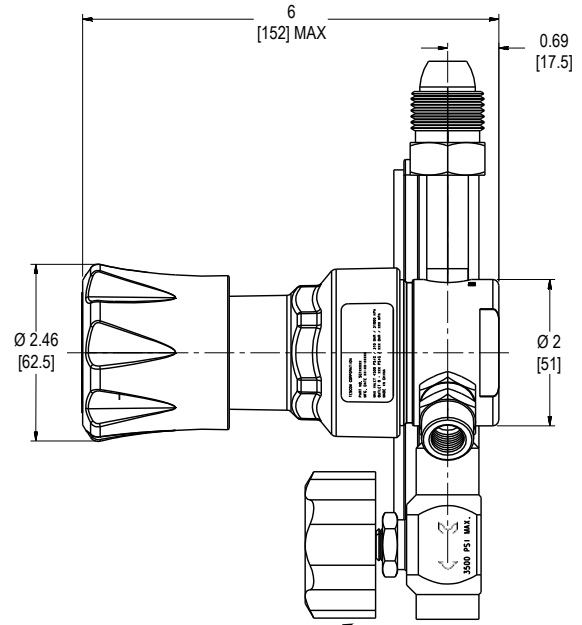
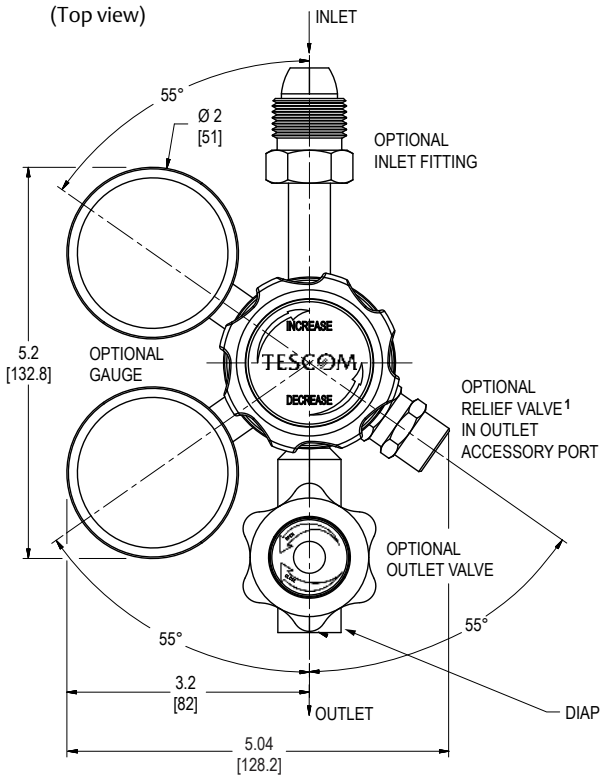

DIAPHRAGM VALVE SHOWN

4 Ports
(Top view)

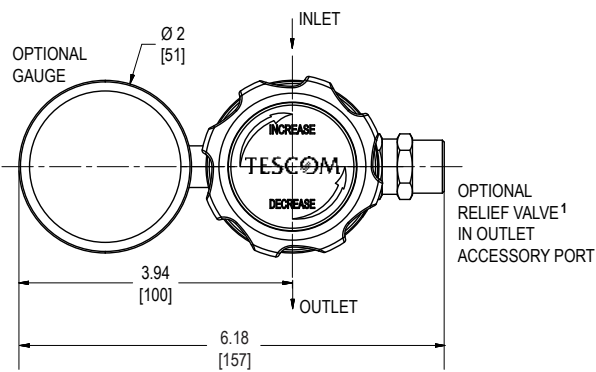

Bottom Mounting

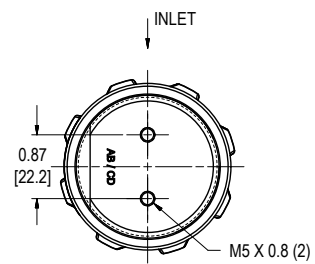

All dimensions are reference & nominal
Metric [millimeter] equivalents are in brackets

SG1 Series Regulator Flow Charts

For more information on how to read flow curves, please refer to the Flow Curves and Calculations document (debul2007x012) in the TESCOM catalog or on www.tescom.com.

C_v = 0.06 Model

Metal Diaphragm

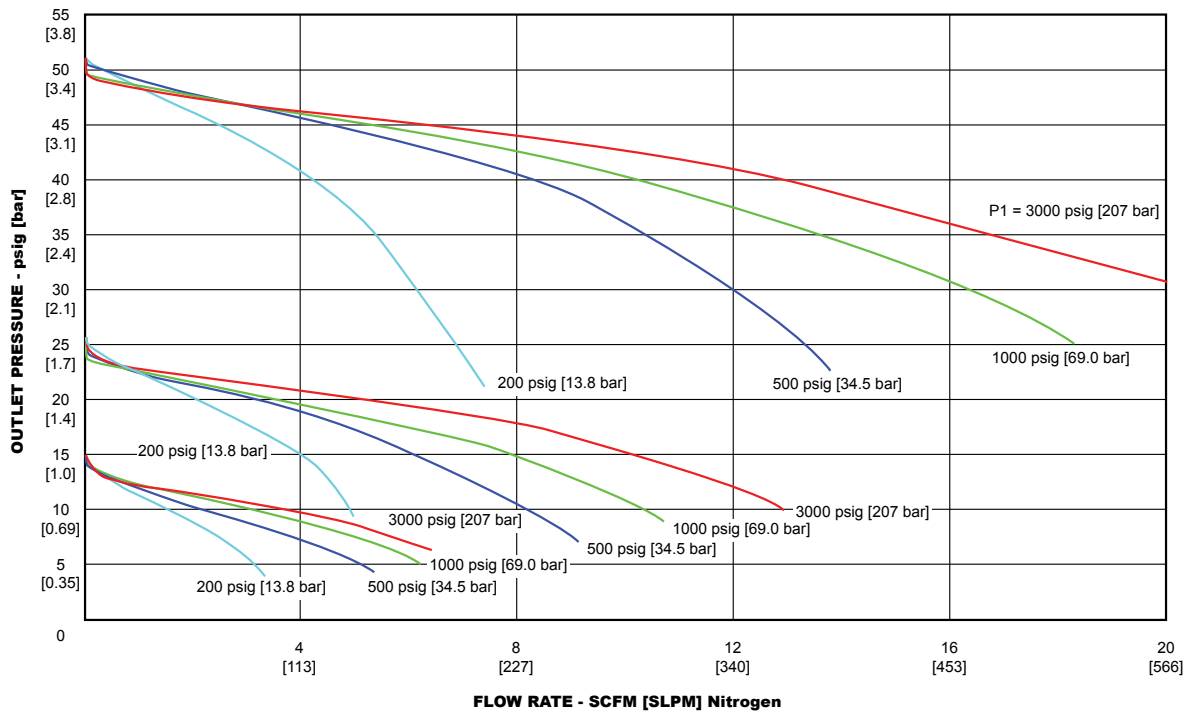
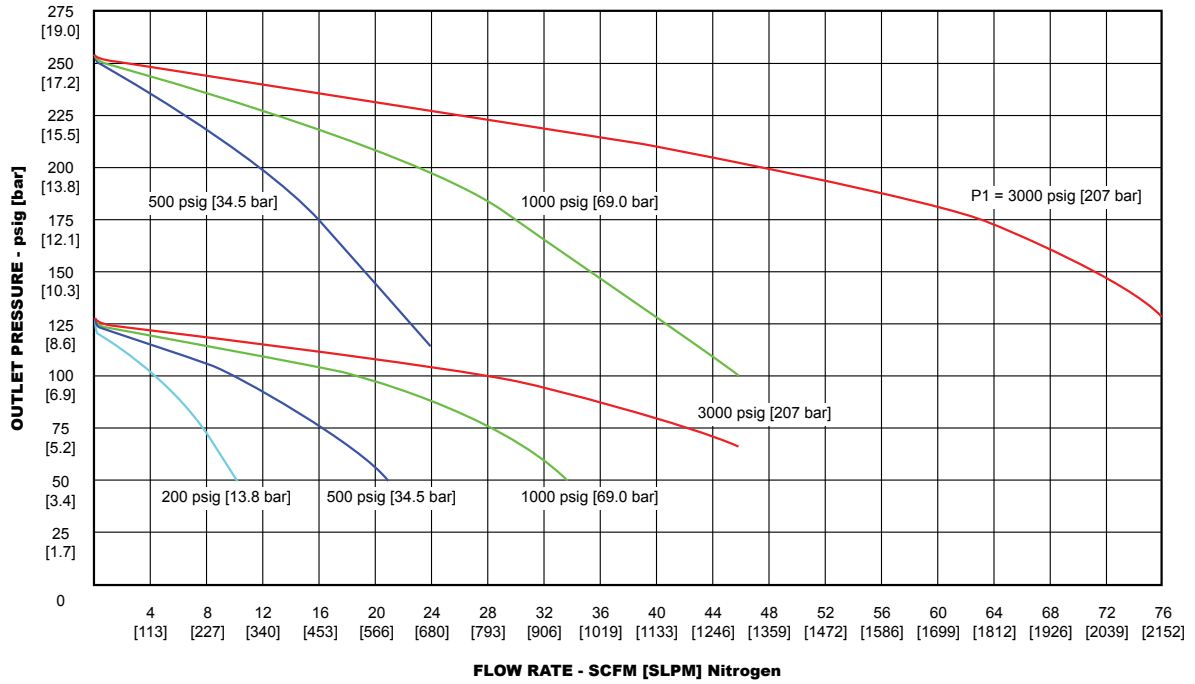

SG1 Series Regulator Flow Charts

For more information on how to read flow curves, please refer to the Flow Curves and Calculations document (debul2007x012) in the TESCOM catalog or on www.tescom.com.

C_v = 0.06 Model Neoprene Diaphragm

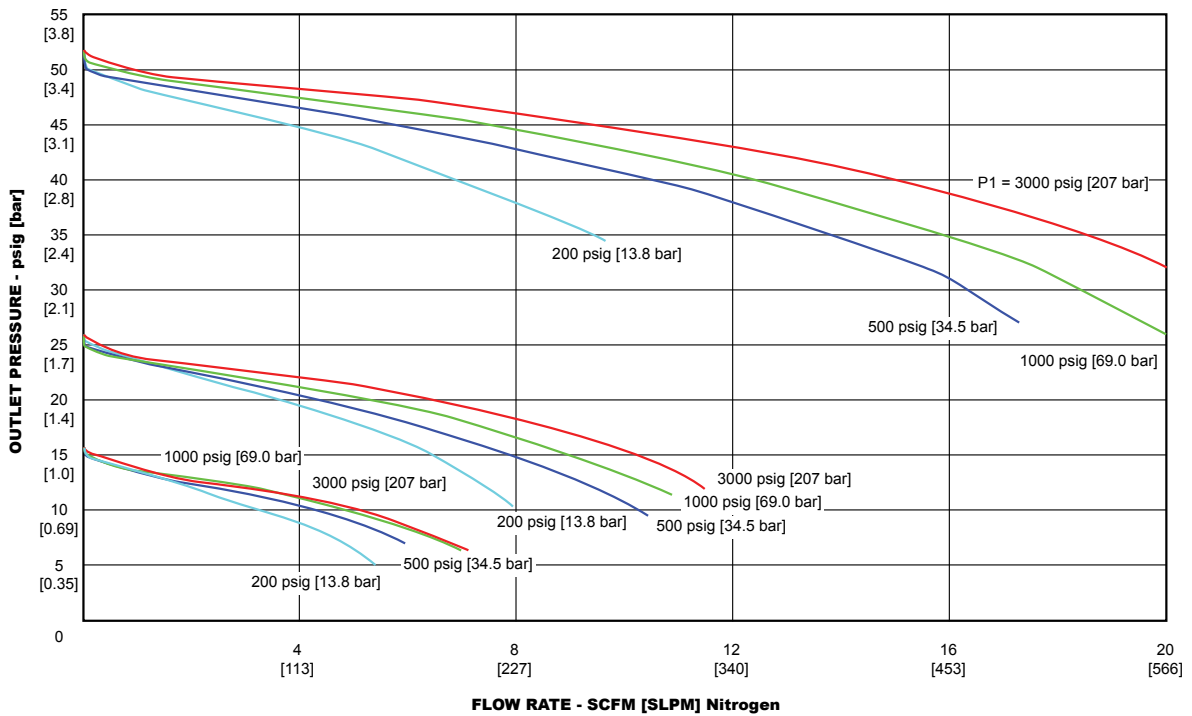
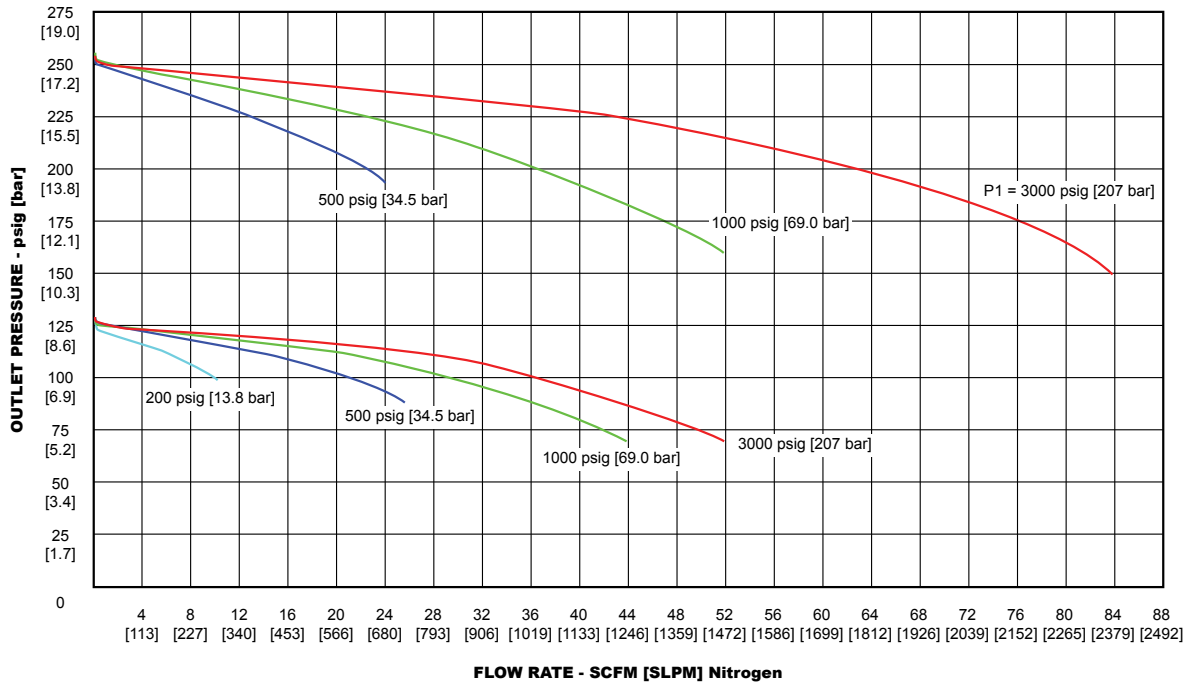

SG1 Series Regulator Flow Charts

For more information on how to read flow curves, please refer to the Flow Curves and Calculations document (debul2007x012) in the TESCOM catalog or on www.tescom.com.

C_v = 0.20 Model

Metal Diaphragm

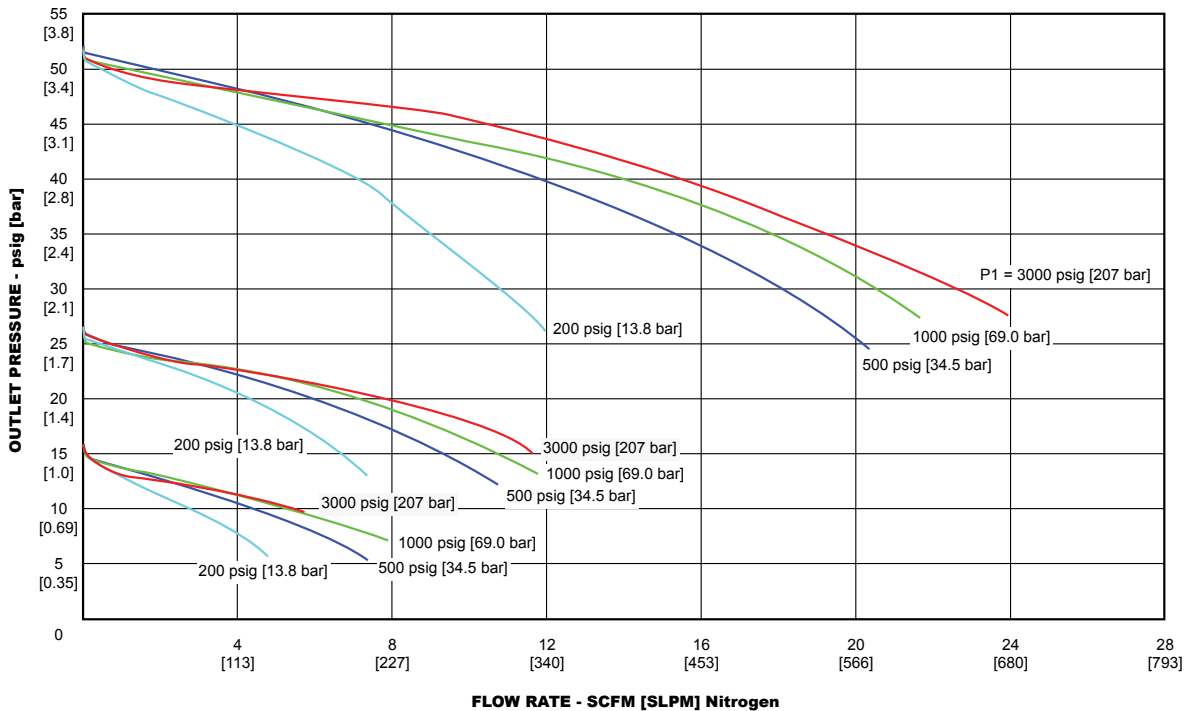
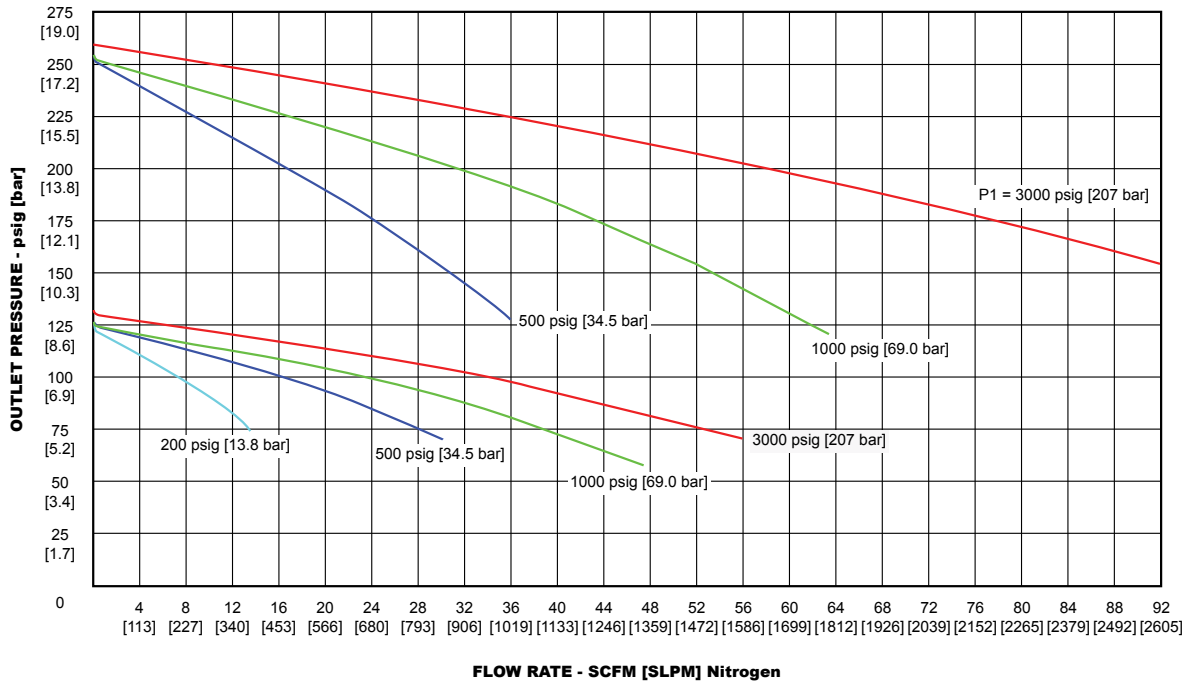

SG1 Series Regulator Flow Charts

For more information on how to read flow curves, please refer to the Flow Curves and Calculations document (debul2007x012) in the TESCOM catalog or on www.tescom.com.

C_v = 0.20 Model Neoprene Diaphragm

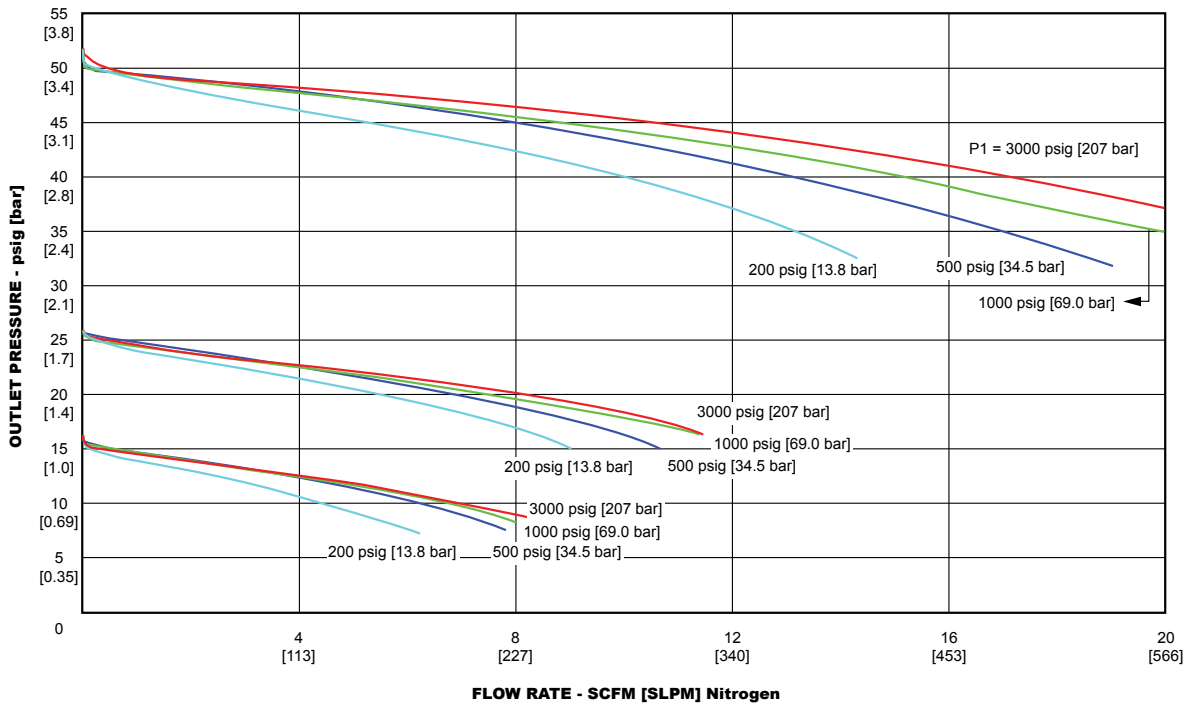
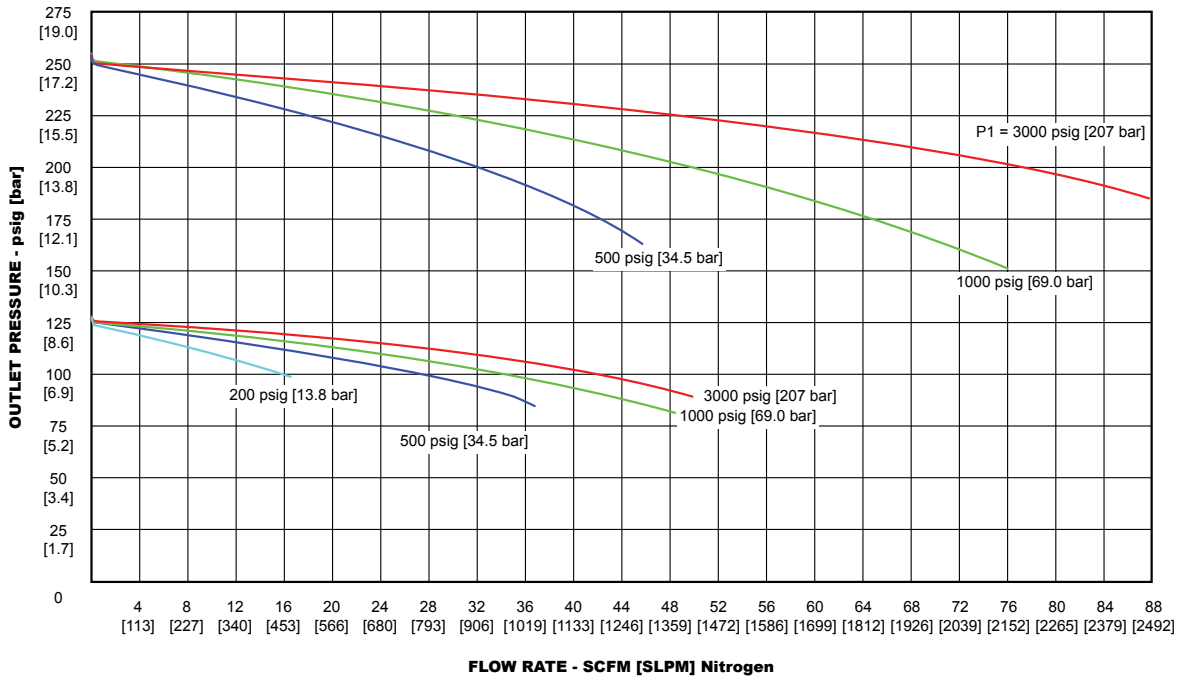

SG1 Series Regulator Part Number Selector

Repair Kits, Accessories & Modifications may be available for this product. Please contact TESCOM for more information.

Base Model

Example for selecting a part number:

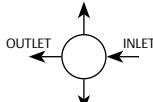
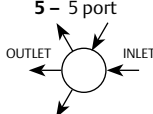
| SG1 | 6 | 3 | 1 | | 4 | 1 | | [Blank] |
|--------------|---|--|--|-------------------|--|-----------------------------------|--|--|
| BASIC SERIES | BODY MATERIAL | OUTLET PRESSURE RANGES | DIAPHRAGM MATERIAL | SEAL MATERIAL | PORTS ² (TOP VIEW) | FLOW C _v | P1 | SEAT MATERIAL |
| SG1 | P – Nickel-Plated Brass 6 – 316L Stainless Steel | 1 – 15 psig / 103 kPa / 1.0 bar * 2 – 25 psig / 172 kPa / 1.7 bar 3 – 50 psig / 345 kPa / 3.4 bar 4 – 125 psig / 862 kPa / 8.6 bar 5 – 250 psig / 1724 kPa / 17.2 bar | 1 – 316L Stainless Steel 2 – Neoprene | Teflon® Buna-N | 4 – 4 port  5 – 5 port  | 1 – 0.06 2 – 0.2 | 4500 psig 31,026 kPa 310 bar 3000 psig 20,684 kPa 207 bar | [Blank] – PCTFE V – Vespel® |
| | | * Consider a two-stage regulator (SG2) if using full range of inlet pressure capabilities | | | | | | |

Accessories

Extension to base model part number:

SG1XXXXXX – **06** **A** **1** **A**

| BASE MODEL NUMBER | CYLINDER CONNECTIONS | GAUGES ² | RELIEF VALVE ¹ | OUTLET VALVE |
|---|---|--|--|--------------|
| 00 – None 01 – CGA 296 02 – CGA 350 C1 – CGA 510 03 – CGA 540 04 – CGA 580 05 – CGA 590 06 – DIN 477-1.1 07 – DIN 477-1.3 08 – DIN 477-1.5 09 – DIN 477-1.6 10 – DIN 477-1.7 11 – DIN 477-1.8 12 – DIN 477-1.9 13 – DIN 477-1.10 14 – DIN 477-1.14 15 – DIN 477-5.54 16 – DIN 477-5.57 17 – DIN 477-5.59 18 – BS 341 (2003) #01 19 – BS 341 (2003) #02 20 – BS 341 (2003) #03 21 – BS 341 (2003) #04 23 – BS 341 (2003) #06 24 – BS 341 (2003) #07 25 – BS 341 (2003) #08 27 – BS 341 (2003) #10 28 – BS 341 (2003) #11 30 – BS 341 (2003) #13 31 – BS 341 (2003) #14 32 – BS 341 (2003) #15 | 0 – None P – Plug(s) A – psi / kPa B – bar / psi | A – None P – Plug 1 – Teflon® Pipe-away | 0 – None A – Diaphragm valve B – Needle valve | |
| Note: Cylinder connections are available in all world areas. | | | | |

¹ The relief valve is not intended to be a "Pressure Relief Device" as defined by ASME Boiler & Pressure Vessel Code - Section VIII, nor is it intended to be a "Safety Accessory" or "Pressure Limiting Device" as defined by the Pressure Equipment Directive (97/23/EC). The relief valve is intended to indicate a potential problem with the regulator and prevent further damage to the regulator. The relief valve is not intended to protect the downstream process equipment.

| ² GAUGE PRESSURE RANGES | |
|---|----------------------------------|
| OUTLET PRESSURE RANGE | OUTLET GAUGE PRESSURE RANGE |
| SG1X1XXXX – 15 psig / 103 kPa / 1.0 bar | 0-30 psig / 200 kPa / 2 bar |
| SG1X2XXXX – 25 psig / 172 kPa / 1.7 bar | 0-30 psig / 200 kPa / 2 bar |
| SG1X3XXXX – 50 psig / 345 kPa / 3.4 bar | 0-60 psig / 400 kPa / 4 bar |
| SG1X4XXXX – 125 psig / 862 kPa / 8.6 bar | 0-160 psig / 1100 kPa / 11 bar |
| SG1X5XXXX – 250 psig / 1724 kPa / 17.2 bar | 0-300 psig / 2000 kPa / 20 bar |
| INLET PRESSURE RANGE | INLET GAUGE PRESSURE RANGE |
| All | 6000 psig / 41,000 kPa / 400 bar |

SG1 Series Rebuild Kits

Rebuild Kits include replacement cartridges, diaphragms, diaphragm seals, lubrication and instruction sheet.

| KIT PART NUMBER | FOR SG PART NUMBER |
|-----------------|--------------------|
| JT389-8927 | SG1PX1X1 |
| JT389-8928 | SG1PX1X2 |
| JT389-8929 | SG1PX2X1 |
| JT389-8930 | SG1PX2X2 |
| JT389-8931 | SG16X1X1 |
| JT389-8932 | SG16X1X2 |
| JT389-8933 | SG16X2X1 |
| JT389-8934 | SG16X2X2 |
| JT389-8927V | SG1PX1X1V |
| JT389-8928V | SG1PX1X2V |
| JT389-8929V | SG1PX2X1V |
| JT389-8930V | SG1PX2X2V |
| JT389-8931V | SG16X1X1V |
| JT389-8932V | SG16X1X2V |
| JT389-8933V | SG16X2X1V |
| JT389-8934V | SG16X2X2V |

TESCOM 电子半导体行业 (HP & UHP) 产品中国独家授权代理

Supex[®]
Pipeline to success

上海盛邦工业装备有限公司

电话/TEL:0086-21-58362880 ,58366231 ,58366243 ,58366238

传真/Fax:0086-21-58314930

Email:info@supex.com.cn

http://www.supex.com.cn



WARNING! Do not attempt to select, install, use or maintain this product until you have read and fully understood the *TESCOM Safety, Installation and Operation Precautions*.

DSG012031X012 © 2012 Emerson Process Management Regulator Technologies, Inc. All rights reserved. 10/2012.
Tescom, Emerson Process Management, and the Emerson Process Management design are marks of one of the Emerson Process Management group of companies. All other marks are the property of their respective owners.

www.tescom.com

EMERSON
Process Management